

SUN MODUL[®]

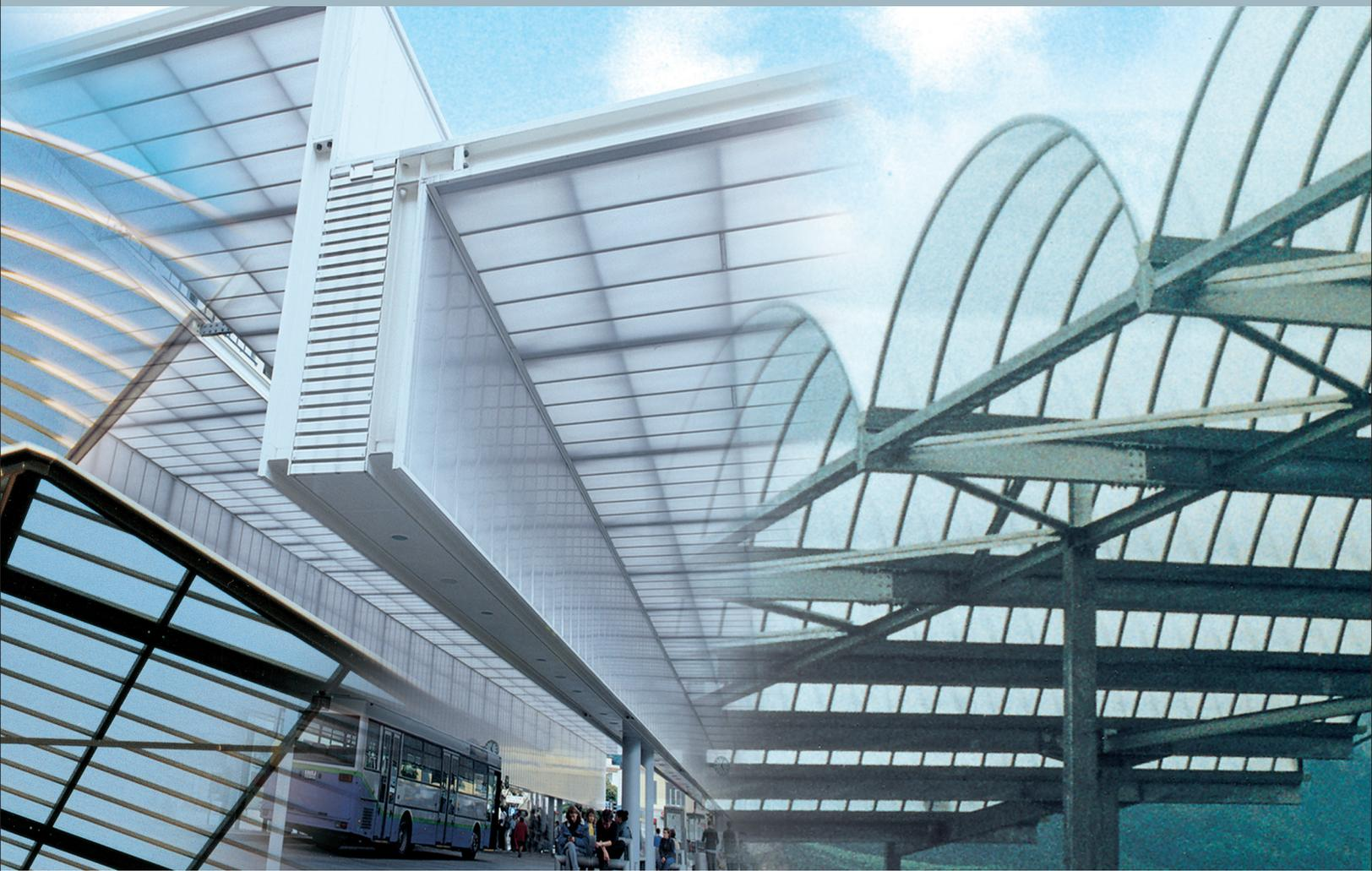

***PATENTED SELF-CARRYING
GLAZING SYSTEM
IN POLYCARBONATE***



AKRAPLAST[®] Sistemi S.p.A.

is a reference in the field of translucent systems, sheets and panels for the building branch, specially regarding polycarbonate products.

Constant attention in the choice of raw materials, commitment in development and improvement of the products as well as technical and commercial support to the customers, are the base of the Company's philosophy.

For 30 years AKRAPLAST Sistemi has been operating all over Europe and on many extra-European markets, offering technologies, products and services which brought the Company to success.

A Transparent World



Organizzazione con Sistema di Gestione certificato
Company with Management System certified

ISO 9001:2008



Quality certification
ISO 9001

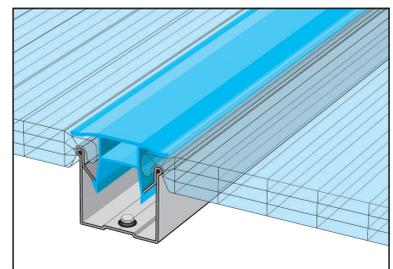
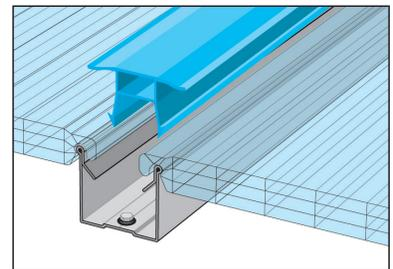
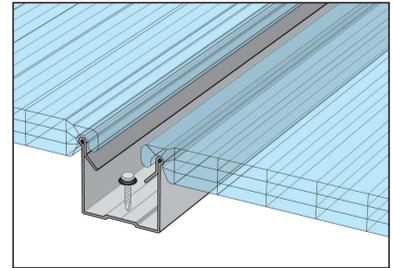
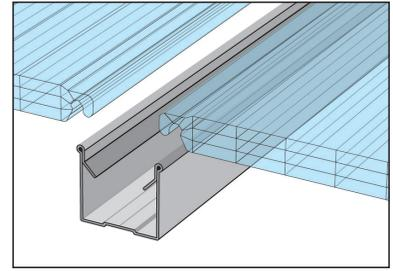
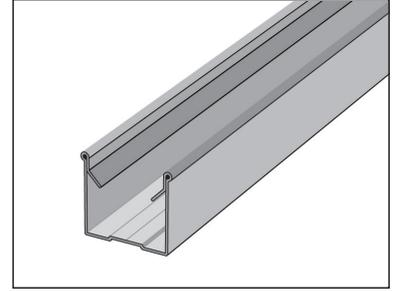
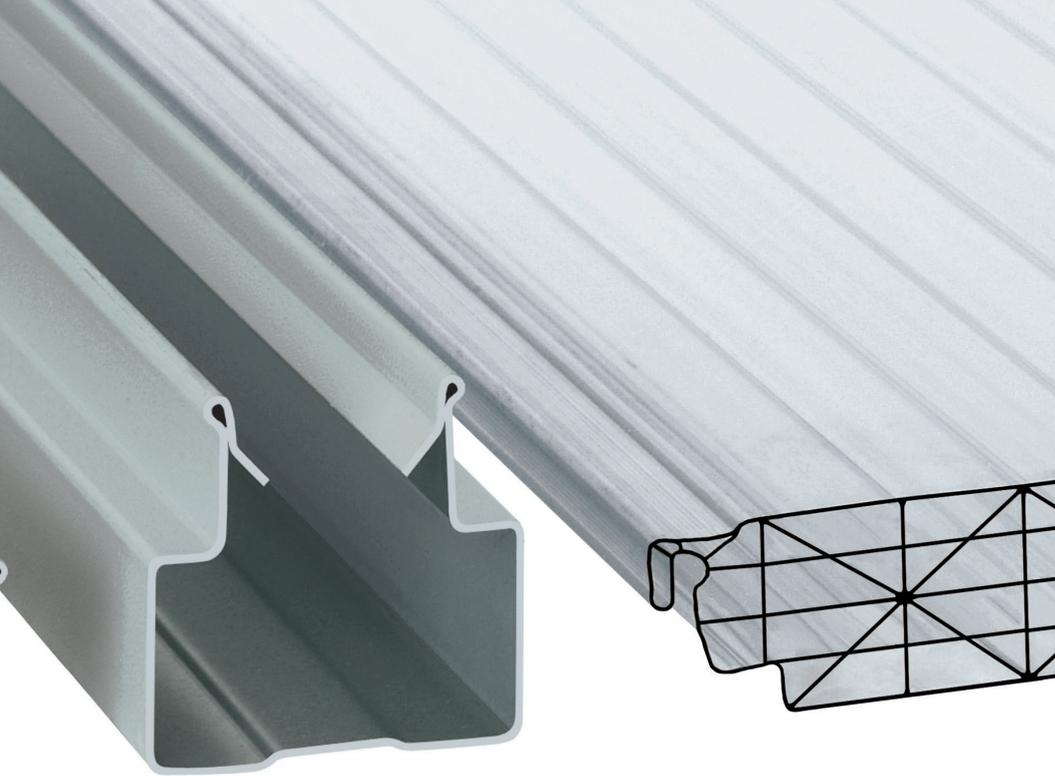

SUN MODUL®

THE COMPLETE SOLUTION FOR GLAZING ROOFS AND WALLS

The patented **SUN MODUL®** system is the result of a long experience in the field of translucent glazing of roofs and walls, as well as domed skylights.

- The **SUN MODUL®** system combines high wind and snow loading capability, water tightness and stability of jointing, with lightness, easy assembly and the external appearance of a continuous surface. These properties make the system particularly well suited to glazing roofs and walls in industrial and commercial buildings and any other high specification applications.

- The special multi-wall polycarbonate panels are hooked onto steel channels and firmly locked with special polycarbonate clip profiles, conferring excellent characteristics to the system for the creation of translucent surfaces of any kind in modern building.

- Extruded from high-grade polycarbonate, the glazing panels provide good light transmission and thermal insulation and are practically unbreakable. With an advanced UV resistant surface coating, weather resistance and long life span are guaranteed.

- The PC clip profiles are produced with the same technical characteristics as the panels.

- The galvanized and plastic coated steel channels are designed to provide very high rigidity. Consequently, the system can be used for wide, unsupported spans.

- The system is completed by a full range of aluminium profiles for frames, seals, opening windows and other accessories for every kind of application.



SUN MODUL®

PANELS - STEEL CHANNELS - CLIP PROFILES

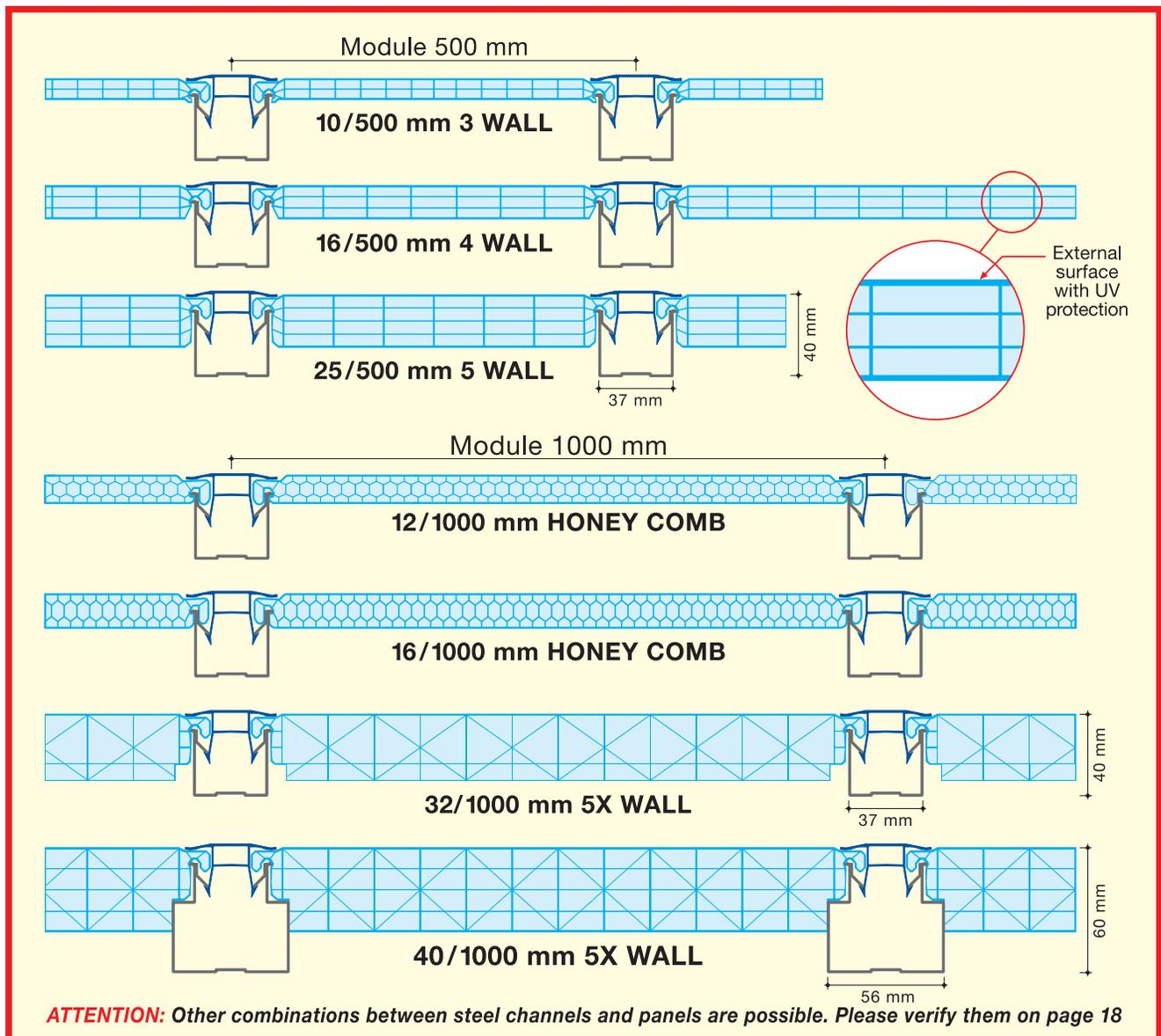

TECHNICAL DATA	module 500 mm (± 2)			module 1000 mm (± 2)				Unit
Panel thickness (nominal)	10	16	25	12	16	32	40	mm
Number of walls	3	4	5	[4]	[4]	5X	5X	n°
Thermal transmittance [U]	2,68	2,04	1,55	2,20	1,99	1,27	1,13	W/m²K
Light transmittance: TRANSPARENT	~ 73	~ 66	~ 61	~ 64	~ 60	~ 60	~ 55	%
OPAL-WHITE	~ 63	~ 57	~ 51	~ 48	~ 43	~ 45	~ 40	%
Total weight of the system								
with STANDARD steel channel	4,3	4,7	5,1	3,2	3,8	4,5	5,4	kg/m²
with MAXI steel channel	-	5,9	6,3	-	4,4	5,1	6,0	kg/m²
Minimum bending radius								
with STANDARD steel channel	2000	3500	5500	2000	3000	-	-	mm
with MAXI steel channel	-	6000	6000	-	-	-	-	mm
Thermal expansion	0,065							mm/m K
Temperature range	-40/+120							°C
Fire classification EN 13501-1	B s1 d0 no dripping					B s2 d0		

10/500
3 WALL

16/500
4 WALL

25/500
5 WALL

UV protection

12/1000
HONEY COMB

16/1000
HONEY COMB

32/1000
5X WALL

40/1000
5X WALL

STANDARD STEEL CHANNEL
galvanized

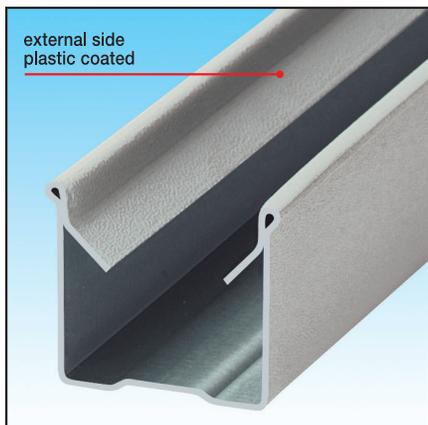

MAXI STEEL CHANNEL
galvanized

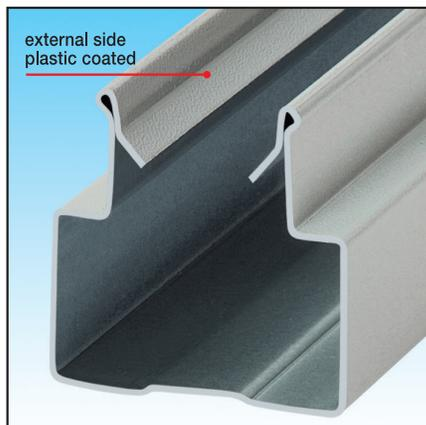

CLIP PROFILE IN PC
UV protected

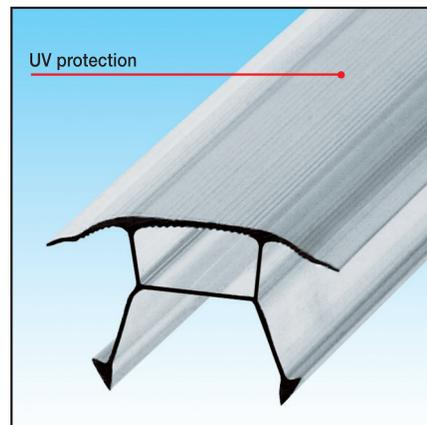



ANCHORAGE

SUN MODUL® guarantees stable and safe anchorage of the panels.

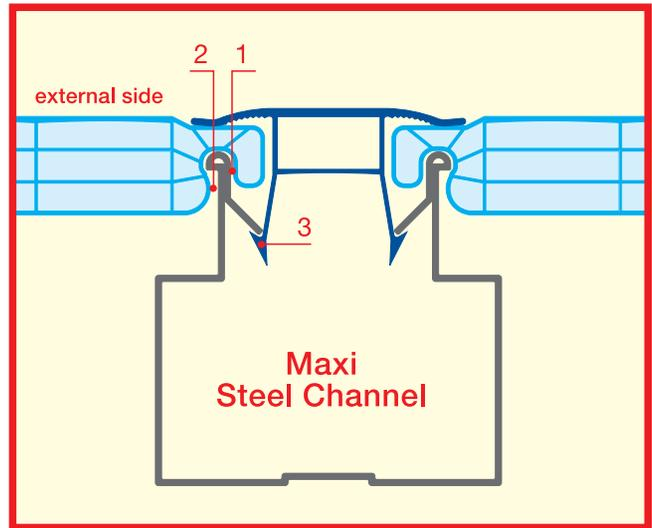
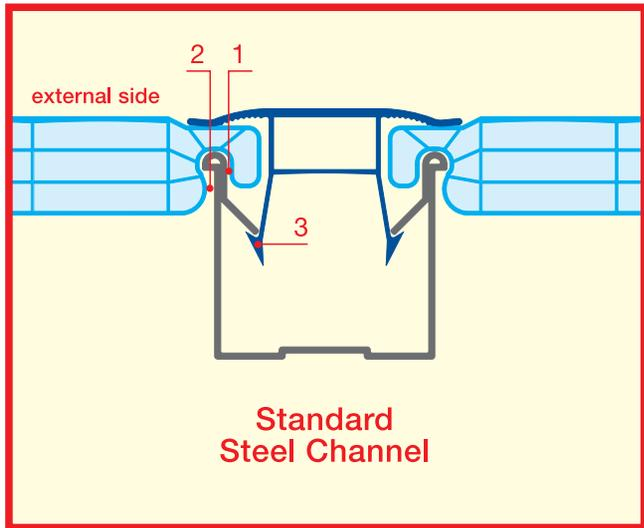

1 - side anchorage **2** - front anchorage **3** - clip profile anchorage

The anchorage of the polycarbonate *panels* is achieved by locking the polycarbonate *clip profile* into the *steel channel*.

The unique shape of the panels and the special profile of the steel channels keep the panels in position against compressive or depressive forces. They remain in place against distributed load (wind and snow) and concentrated (impact) load.

WATER TIGHTNESS

SUN MODUL® guarantees excellent water tightness.

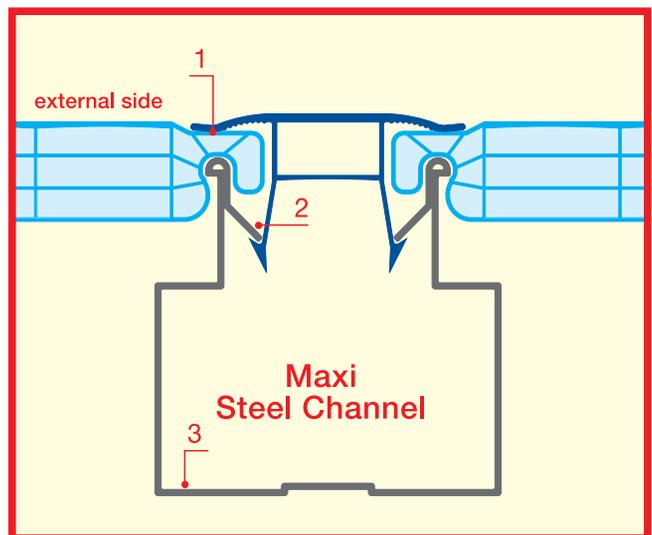
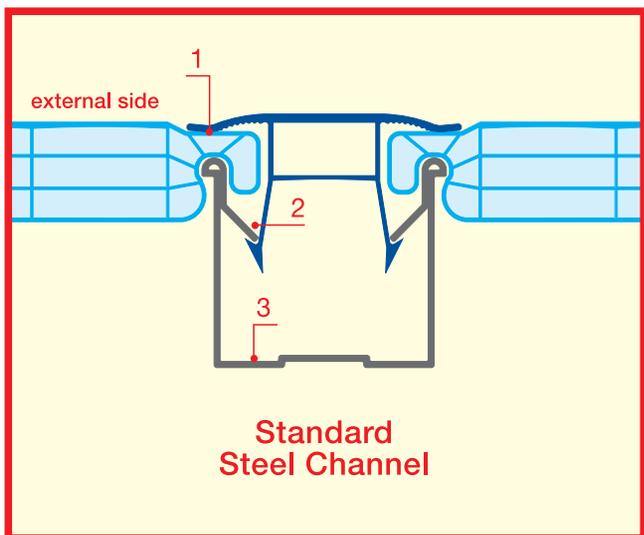

1 - pressure point **2** - primary draining **3** - ultimate draining

The polycarbonate *panels* are locked in place in the *steel channels* by the polycarbonate *clip profile*, so the panels are not perforated by fixings thus preventing infiltration of dust and moisture.

Eventually penetrated microelements can flow outside by the primary draining.

The particular shape of the *steel channel* guarantees secondary draining of infiltrations and condensates, without interfering with fixing screws.



ACCEPTABLE SPANS

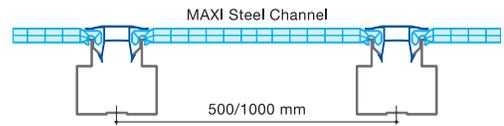

STANDARD Steel Channel

MAXI Steel Channel

Module 500 mm ——— Module 1000 mm - - - - Module 500 mm ——— Module 1000 mm - - - -

Wall 2 supports

F max = 1/50

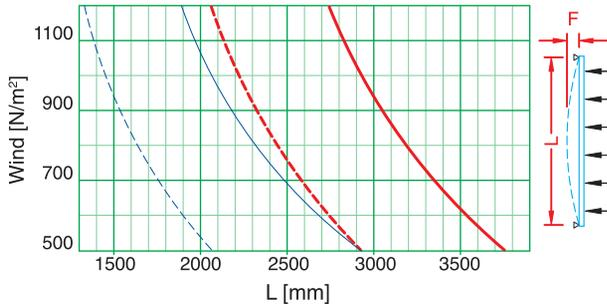

Wall 4 supports

F max = 1/50

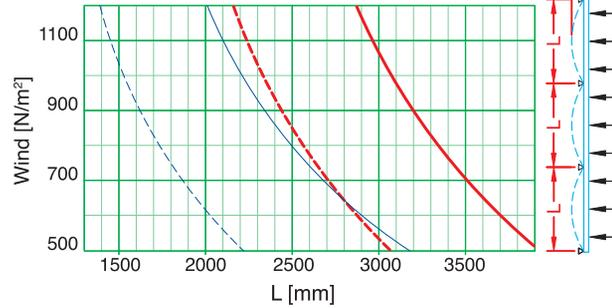

Roof 2 supports

Slope 9%

F max = 1/100

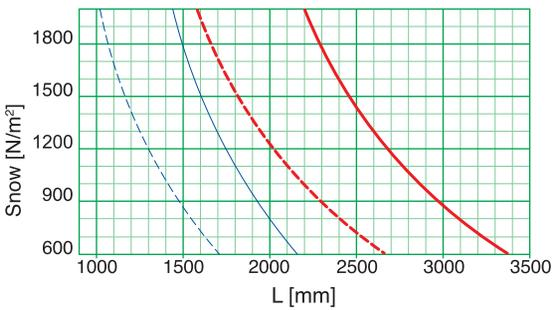

Roof 4 supports

Slope 9%

F max = 1/100

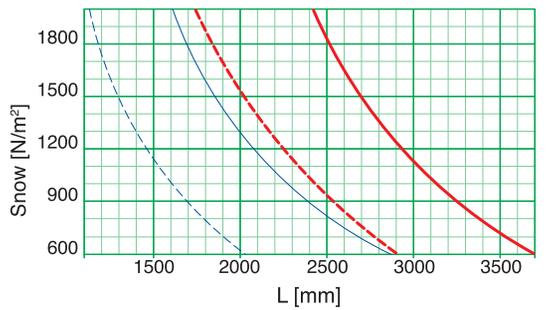

Curved Roof

H = 15% C

Wind = 50 daN/m²

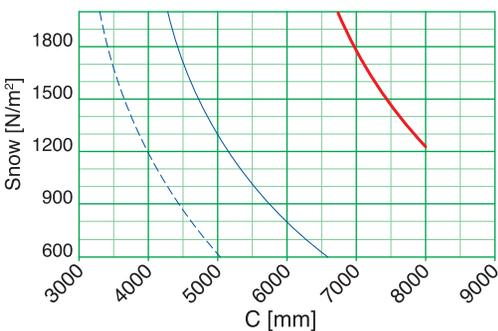

Curved Roof

H = 25% C

Wind = 50 daN/m²

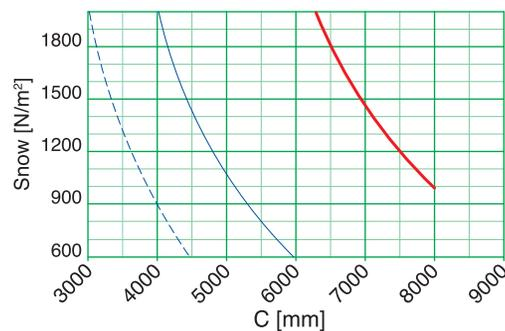

NOTE: The span values indicated are referred to the conditions specified in each graph. For span evaluations under different conditions please ask for a special verification.

SUN MODUL®

WALL / NORTHLIGHT

For vertical and inclined applications the **SUN MODUL®** system is ideal for the creation of aesthetically pleasing walls and northlights with excellent thermal insulation. The system is particularly suitable for big translucent external and internal surfaces in commercial and industrial buildings, as well as in sport sites.

Due to the different possibilities to combine the 2 panel modules in the various thicknesses and the 2 types of steel channel, the best solutions regarding wind loads and thermal insulation are obtained.

The components of the system are supplied on size for the customer's purpose in full height; there is no interruption in the surface. The fact that no fixings perforate the panel guarantees free thermal expansion.

The system is completed by a full range of aluminium profiles for framing and fixing; on size produced window frames, to be opened manually or with motor, are perfectly integrated in the surface, as they are cladded with the same elements as the wall. (See list on pages 15 and 16).

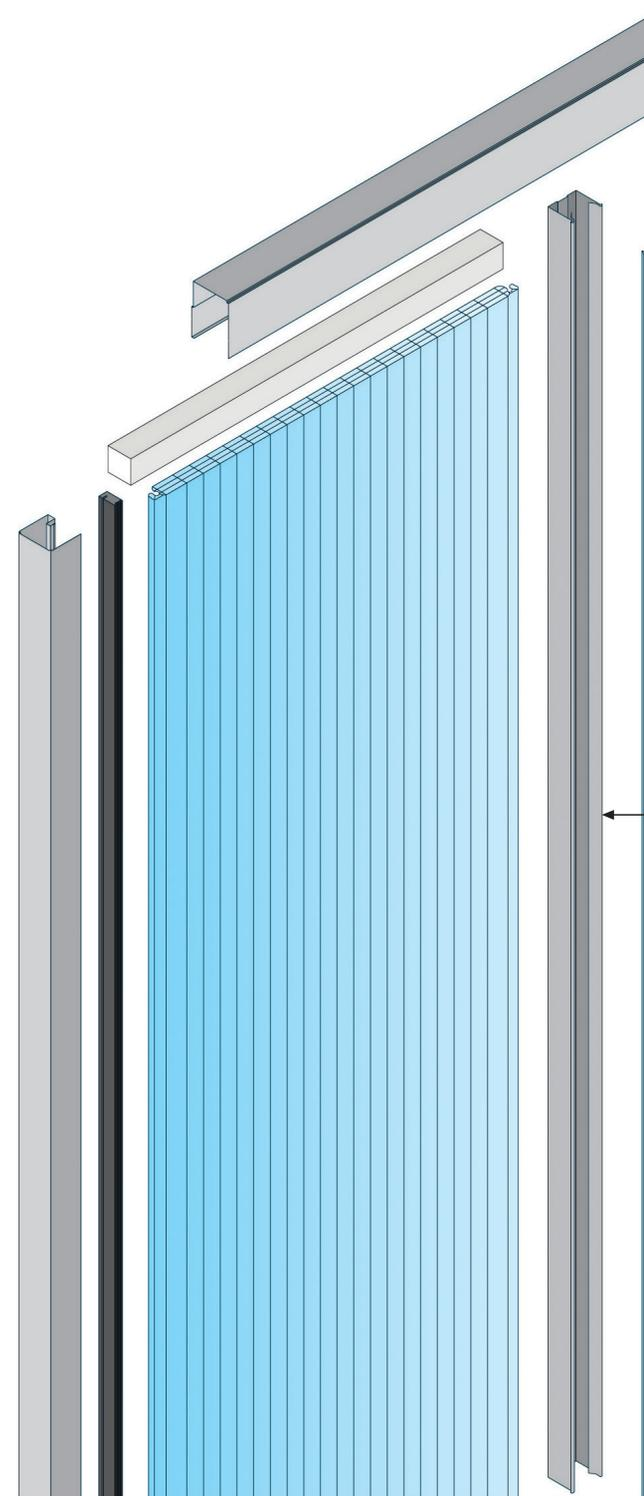
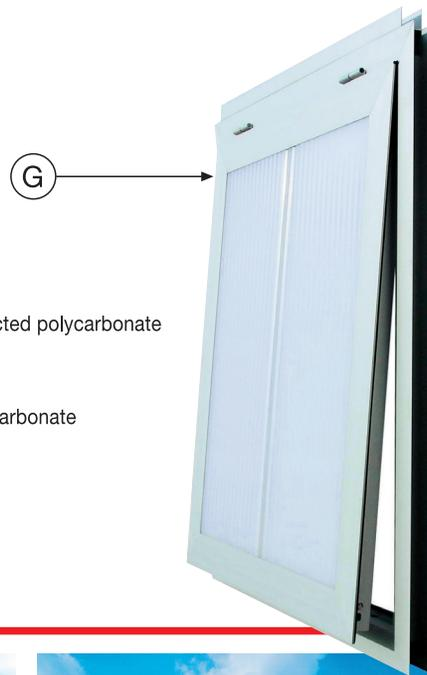

- (A) SUN MODUL® panel in UV protected polycarbonate
- (B) Steel channel
- (C) Clip profile in UV protected polycarbonate
- (D) Framing profile in aluminium
- (E) PE-Inlay
- (F) Gasket
- (G) Aluminium window



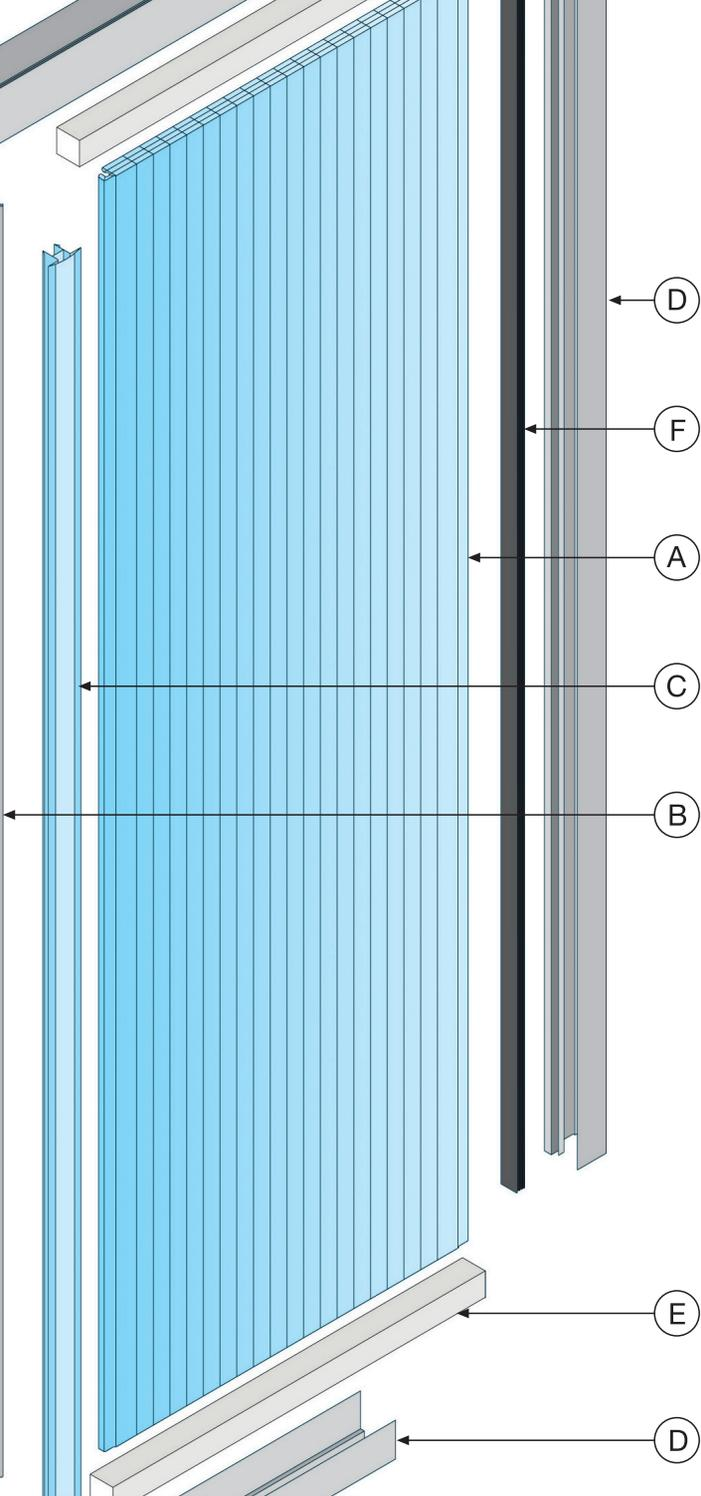

FIXING WITH TOP PROFILE M611



FIXING WITH BOTTOM PROFILE M620

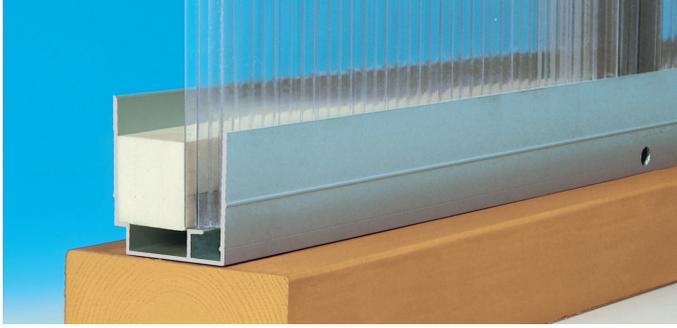

FIXING WITH TOP PROFILE M615



FIXING WITH BOTTOM NORTHLIGHT PROFILE M628

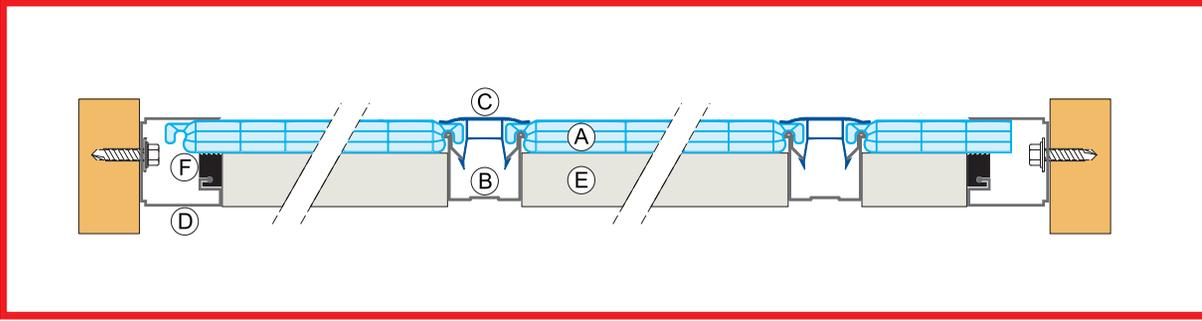

SUN MODUL®

ROOFLIGHTS / NORTHLIGHTS

Due to the excellent water tightness of the patented locking system, high resistance to loads and low overall weight, the **SUN MODUL®** system is particularly well suited to low-pitch roofing applications, as well as traditional northlights.

A wide range of options regarding thermal insulation and load resistance can be obtained by combining various thicknesses of glazing panels and the two standard steel channel profiles.

System components are supplied to length, to minimise joints in the length of the rooflights. The length of individual components is limited only by transport.

The system is completed by a full range of options including manually or electrically operated window frames for ventilation. (See list on pages 15 and 16).

- (A) UV protected polycarbonate glazing panel
- (B) Steel channel
- (C) UV protected polycarbonate clip profile
- (D) Aluminium frame profile
- (E) PE-Inlay
- (F) Seal
- (G) Aluminium window

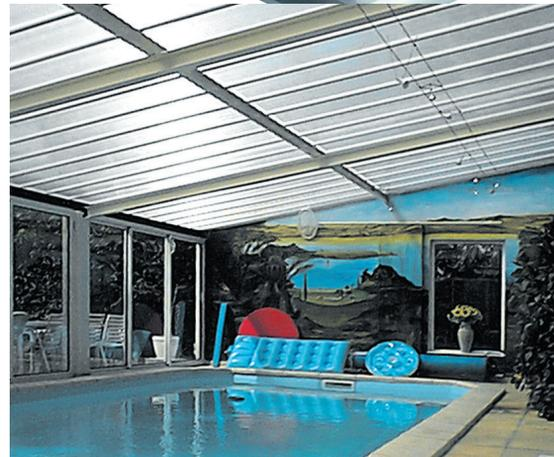
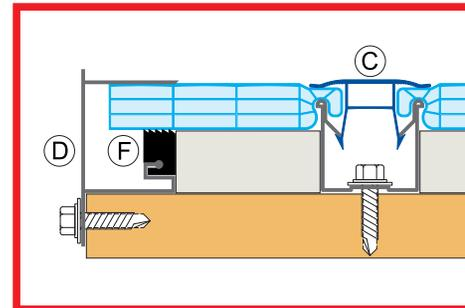
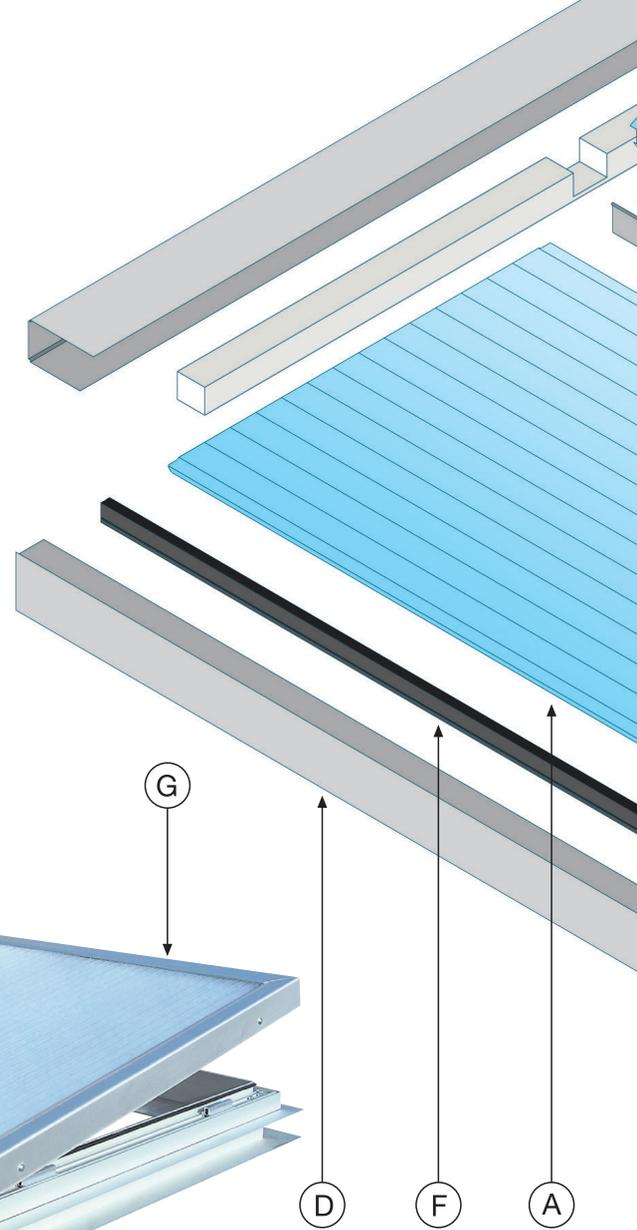

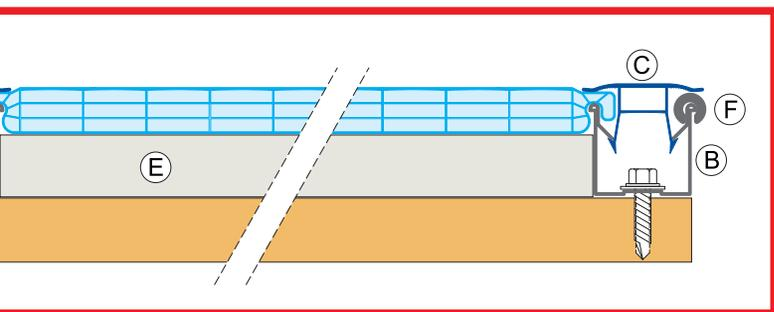

**FIXING ON TOP
WITH ROOF BORDER PROFILE M652**



**FIXING AT BOTTOM
WITH BORDER PROFILE M651**

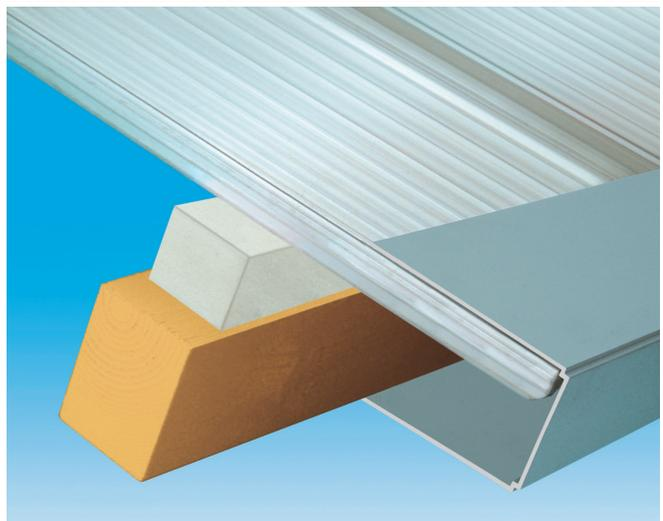

SUN MODUL®

CURVED & BARREL VAULT ROOFLIGHT

SUN MODUL® offers excellent advantages in its curved glazing applications. The curved steel channels and patented locking system provide extremely high load resistance, excellent water tightness and stability, with very low overall weight.

A range of system components is available, providing the capability to construct self-supporting roofs with free spans up to approximately 8m, depending on the radius to curve.

System components are supplied to required length, to minimise joints in the length of the rooflight. The length of individual components is limited only by transport. The system is completed by a full range of options including manually and electrically operated window frames for ventilation. (See list on pages 15 and 16).

- (A) UV protected polycarbonate glazing panel
- (B) Steel channel (radius on request)
- (C) UV protected polycarbonate clip profile
- (D) Aluminium frame profile
- (E) PE-Inlay
- (F) Seal
- (G) Aluminium window
- (H) Front section panel

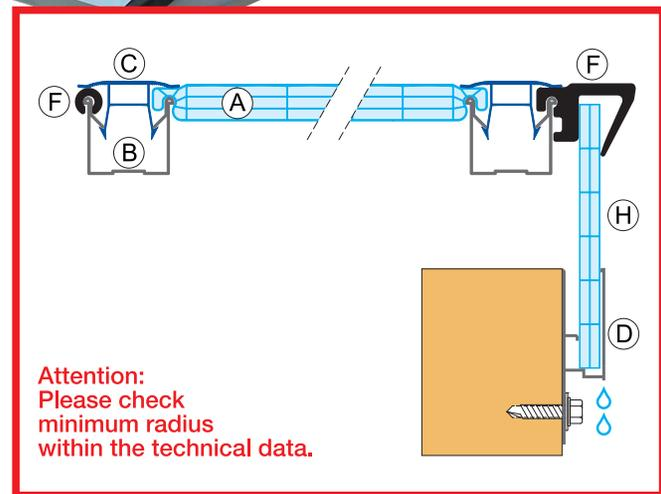
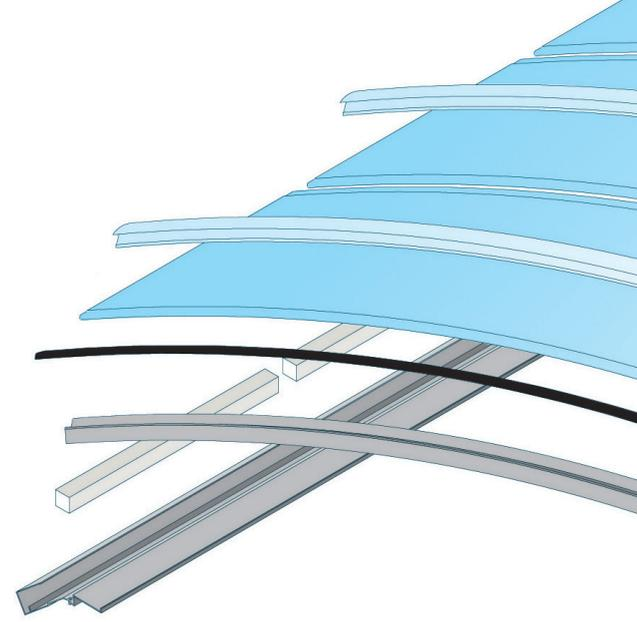

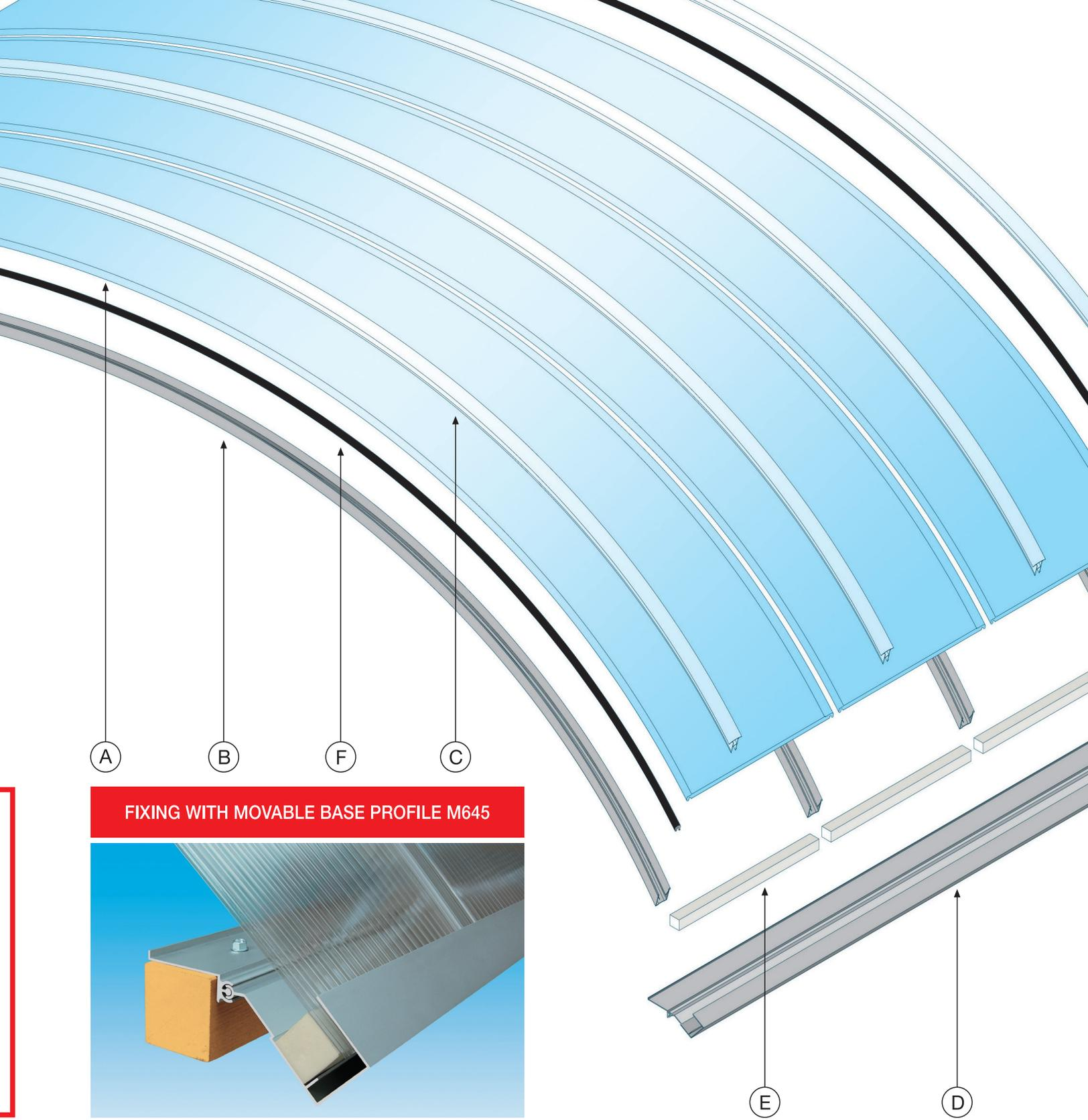

FIXING WITH MOVABLE BASE PROFILE M645

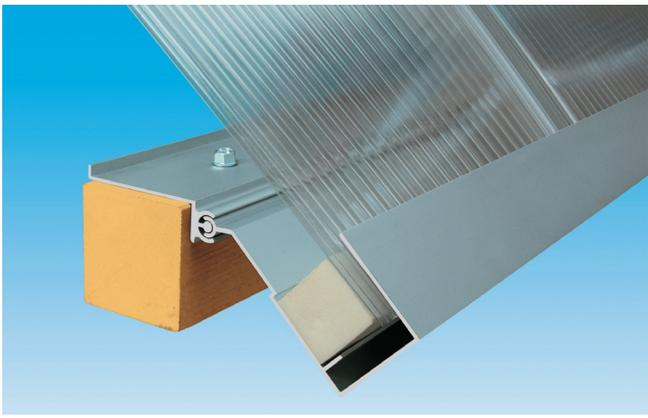

FRONT SECTION WITH GASKET M752



FIXING WITH BOTTOM PROFILE FOR FRONT SECTION M658



SUN MODUL®

IN COMPOSITE PANEL ROOFS

A special gasket in EPDM for the lateral connection with sandwich panels and profiled elements (straight or curved) has been developed for the **SUN MODUL®**.

In low pitch roof applications, long skylights, without interruption can be obtained (limited only by transport). No fixings through the panels are needed, so thermal expansion without problem is possible. Furthermore, high thermal insulation can be obtained.

In case of applications in domed roofs, the high load resistance given by the bent steel channels allow the construction of selfcarrying skylights with big free spans and of rooflights that bear high snow loads.

- (A) SUN MODUL® Panel in UV protected polycarbonate
- (B) Steel channel
- (C) Clip profile in UV protected polycarbonate
- (D) Fixing profile in aluminium
- (F) Gasket in EPDM
- (G) Sandwich panel (not supplied by Akraplast)

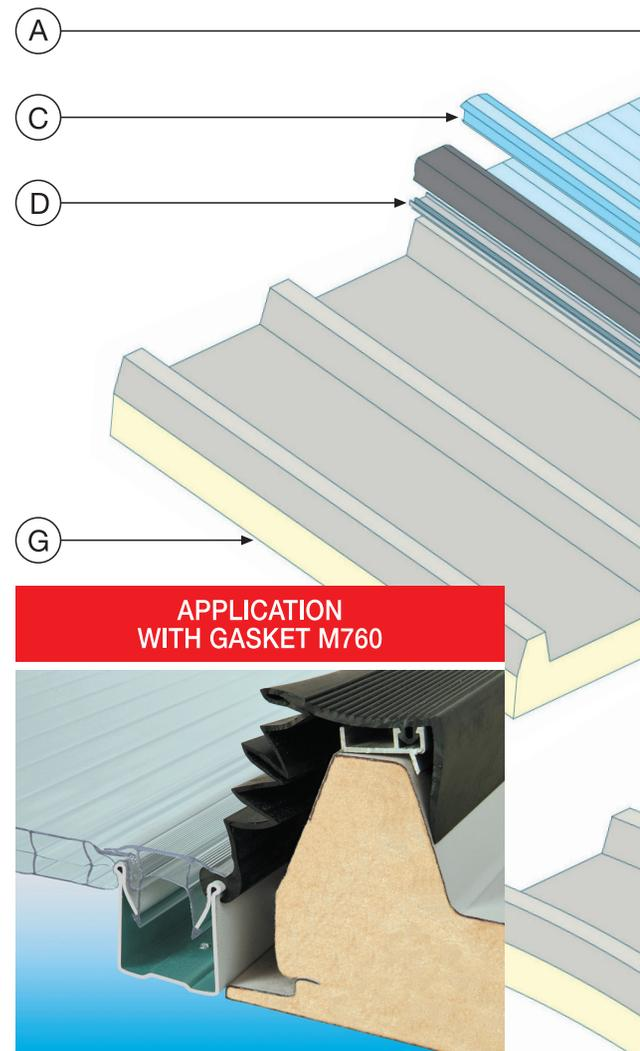
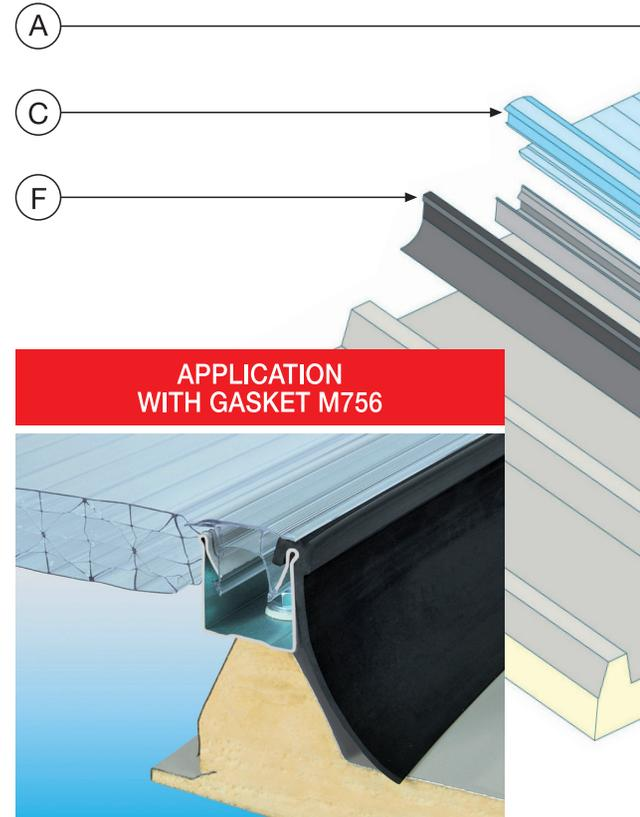

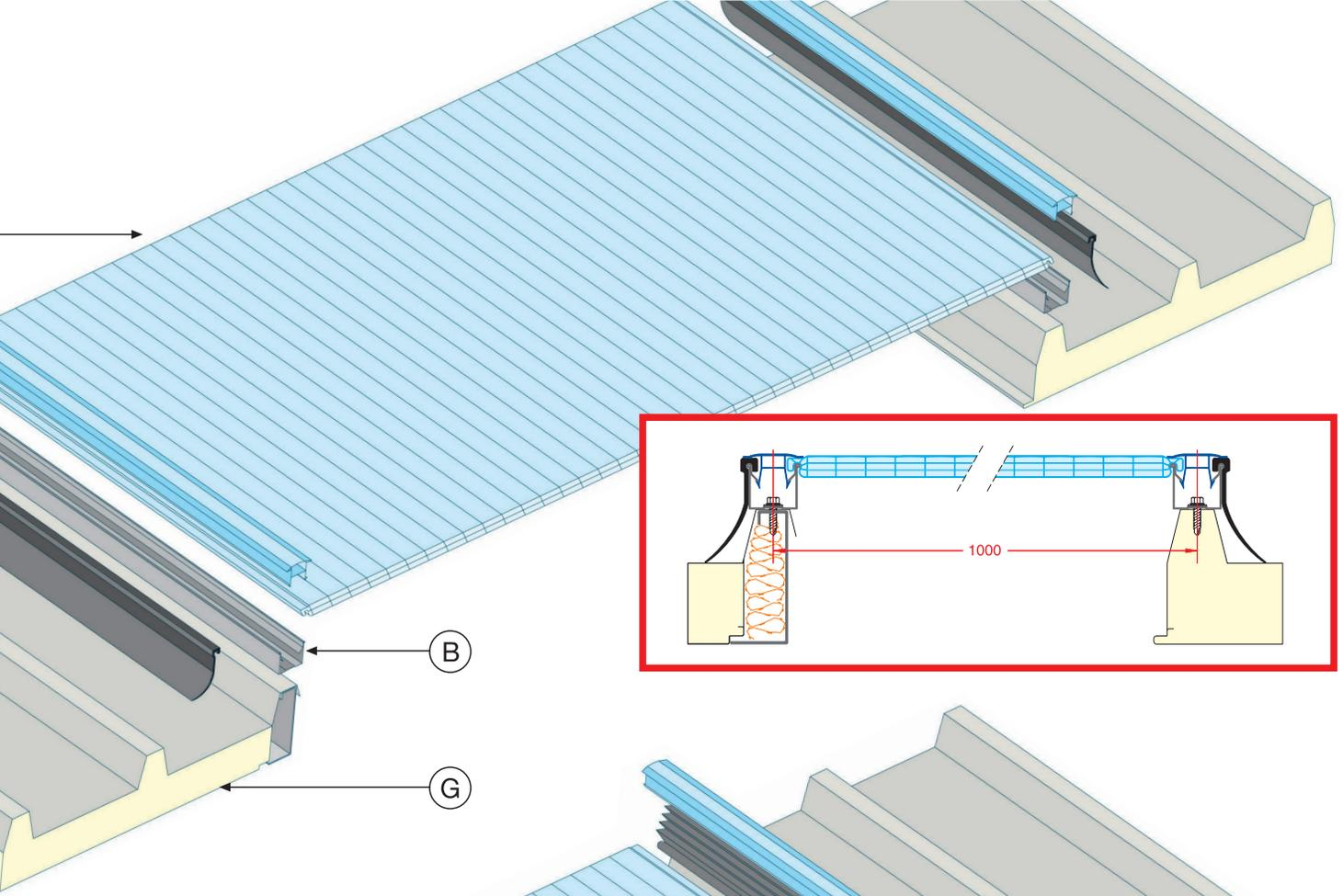

(B)

(G)

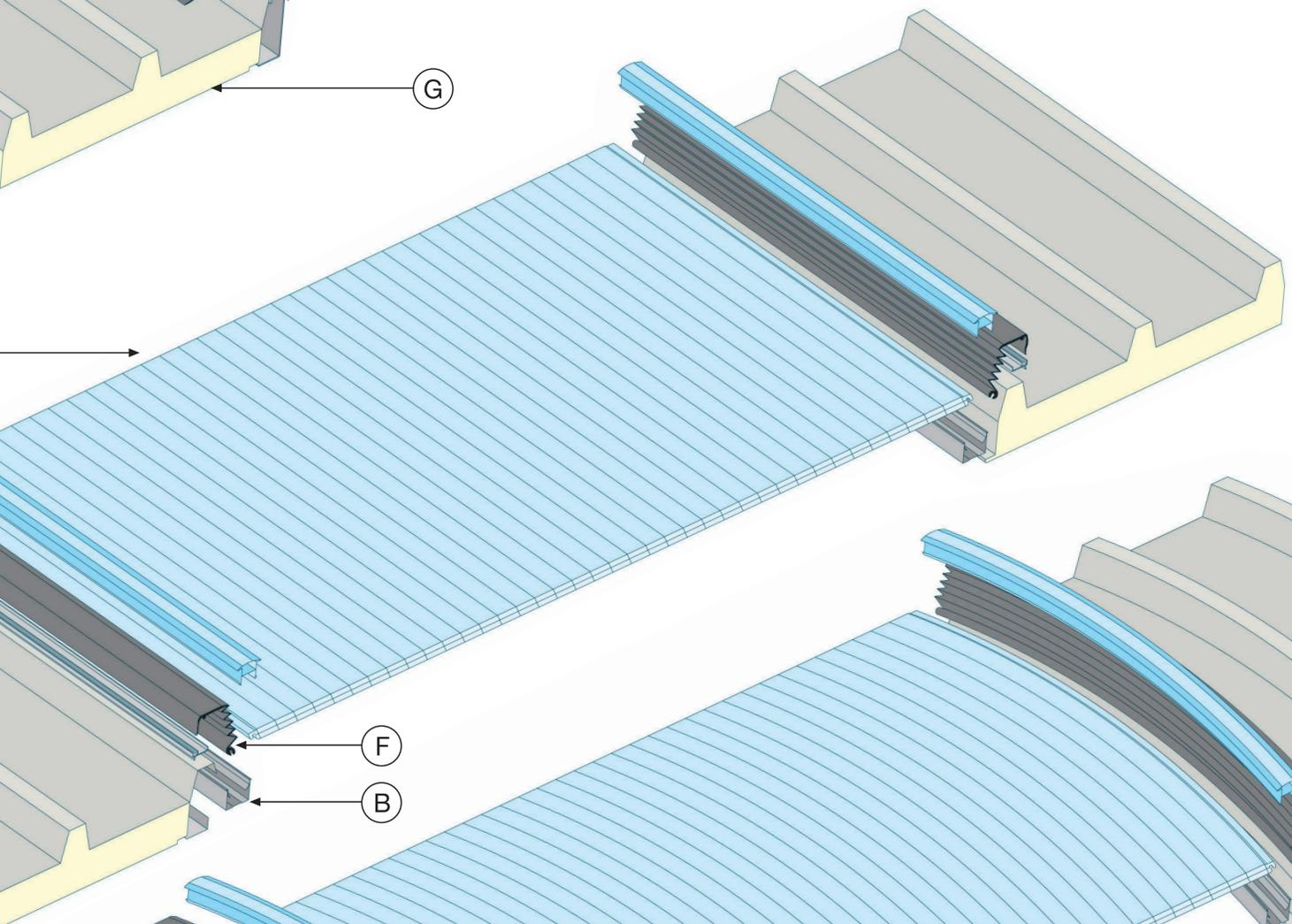

(F)

(B)

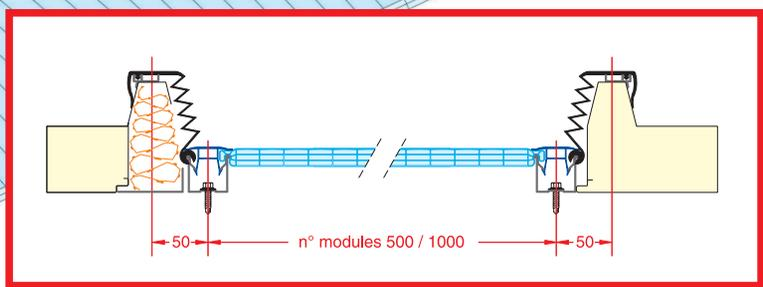
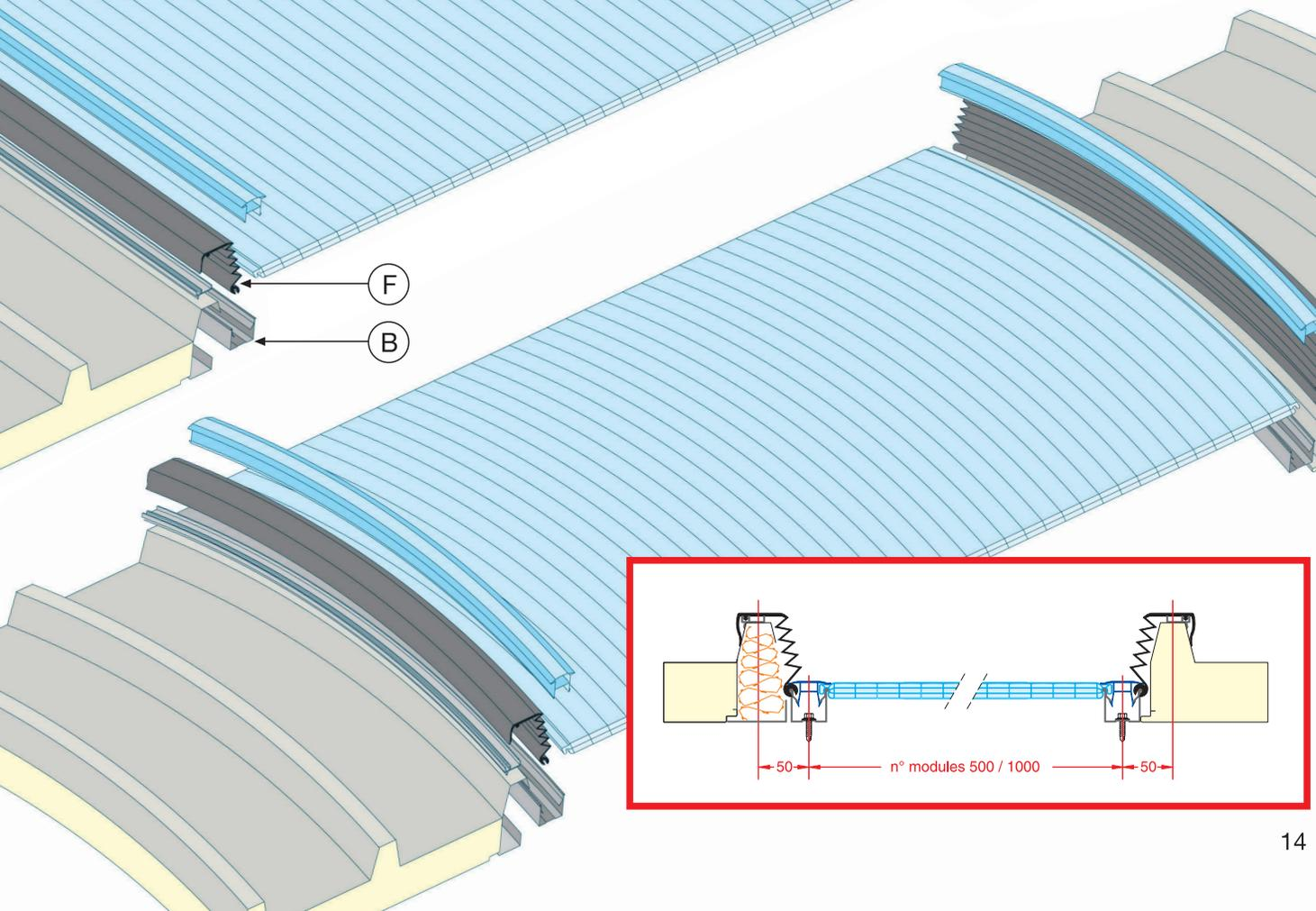



FRAMING PROFILES for Standard Steel Channel

in anodised aluminium (6 m lengths)

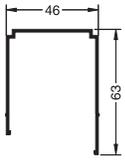

M 610
Top profile

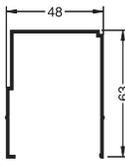

M 611
Top profile

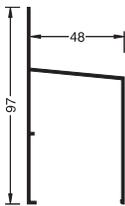

M 615
Top profile

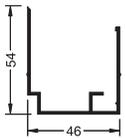

M 620
Bottom profile
with draining hole

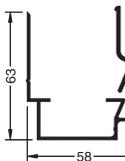

M 622
Bottom profile
with draining hole

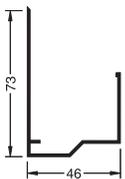

M 628
Shed profile

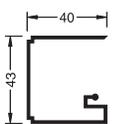

M 630
Side profile
(to be combined with gasket
M732-M734-M736)

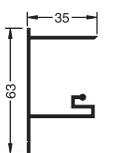

M 635
Side profile
(to be combined with gasket
M732-M734-M736)

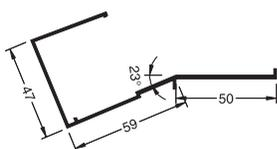

M 643
Base profile
for height / chord 10%

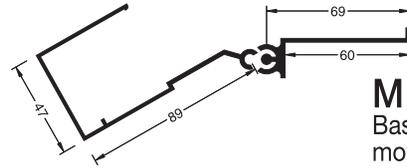

M 645
Base profile with
movable border profile

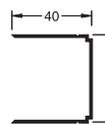

M 650
Border profile

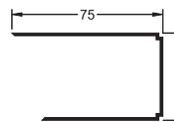

M 651
Border profile

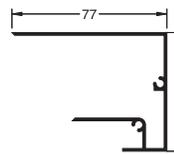

M 652
Border profile
for roof

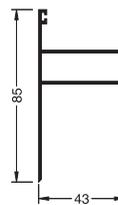

M 655
for window frames

FRAMING PROFILES for generic use

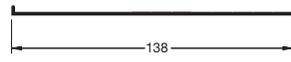

M 626
Special bottom profile

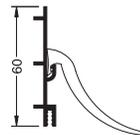

M 640
Top wall profile
with gasket

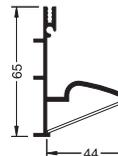

M 642
Bottom wall profile
with cladding piece

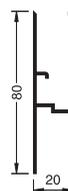

M 658
Bottom profile for front
sections for sheet
thickness 10/16 mm



M 660
for sandwich panels



FRAMING PROFILES for Maxi Steel Channel

in anodised aluminium (6 m lengths)

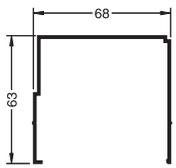

M 661
Top profile



M 671
Bottom profile
with draining hole

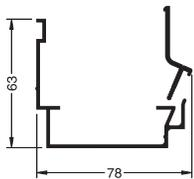

M 672
Bottom profile
with draining hole

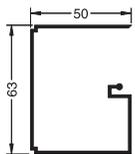

M 680
Side profile for
Sun Modul 16-25 mm
(to be combined with gasket M734 - M736)

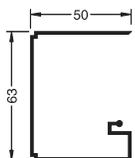

M 681
Side profile for
Sun Modul 32-40 mm
(to be combined with gasket M734 - M736)

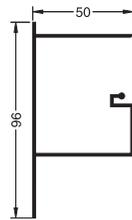

M 685
Side profile for
Sun Modul 16-25 mm
(to be combined with gasket M734 - M736)

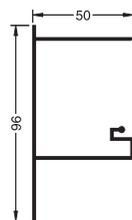

M 686
Side profile for
Sun Modul 32-40 mm
(to be combined with gasket M734 - M736)

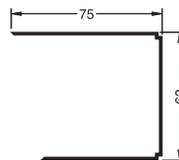

M 691
Border profile

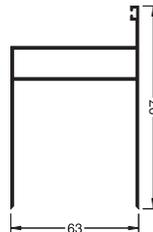

M 695
for window frames

Inlays in PE

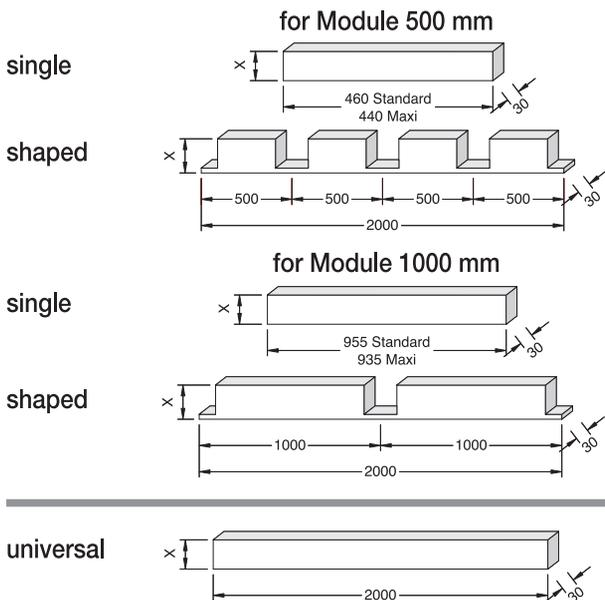

Gaskets in EPDM

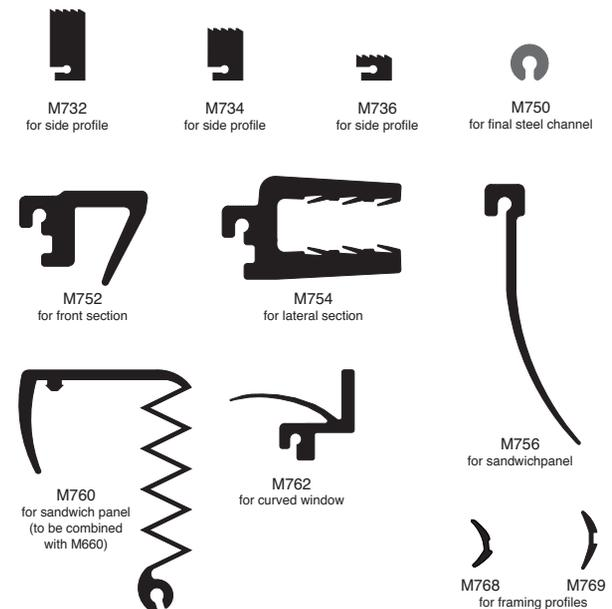



WARRANTY and CERTIFICATES

10-YEARS WARRANTY

SUN MODUL® panels and clip profiles are protected against UV rays on the external side. In Europe they are covered by **10 YEAR WARRANTY** from the date of purchase against yellowing and weather damages (hail. etc.).

For Non-European Countries the warranty may have a different duration.

For further details, please ask for the Warranty Certificate.

CERTIFICATES

A series of tests have been carried out on the **SUN MODUL®** system, in order to confirm it's most significant properties.

The below listed tests and certificates are available; further detailed information about the elements / combinations, on which the tests have been carried out, may be supplied on request.

TYPE of TEST / CERTIFICATE	CERTIFYING AUTHORITY or INSTITUTE
DURABILITY <ul style="list-style-type: none">• Evolution during time of light transmission and impact strength	CSTB (France) - n° ED/02-0010
TIGHTNESS <ul style="list-style-type: none">• Air tightness• Water tightness	CTBA (France) - n° 02/PC/PHY/210 CTBA (France) - n° 02/PC/PHY/210
MECHANICAL PROPERTIES <ul style="list-style-type: none">• Resistance to compressive and depressive loads• Resistance of fixings to tearing and deformation	Istituto Giordano (Italy) - n° 174369 ETANCO (France) - n° 30712; 30713
THERMAL PROPERTIES <ul style="list-style-type: none">• Coefficient of thermal conductivity $U = W/m^2K$	CSI (Italy) - n° 110301/09
SOLAR PROPERTIES <ul style="list-style-type: none">• Energy transmission• Light transmission and reflection	Istituto Giordano (Italy) - n° 171329 Istituto Giordano (Italy) - n° 171329
ACOUSTIC PROPERTIES <ul style="list-style-type: none">• Coefficient of acoustic insulation	CSI (Italy) n° 31/DC/ACU/04 - 58/DC/ACU/04
FIRE CLASSIFICATION <ul style="list-style-type: none">• Italy: Class 1• France: Class M2• Germany: Class B1• Switzerland: Class 4.1• Great Britain: Class 1• Slovenia: Class 1• Poland: not flame spreading	Ministero dell'Interno - Direz. gen. protezione civile SME (SNPE) - n° 11880-04 MPA BAU (Hannover) - n° P ND504-488 EMPA (Dübendorf) - n° 172 518/1 Warrington Fire Research Centre - n°116935 ZAG (Lubjana) - n° P 604/99-530-1 ITB (Warszawa) - n° 845/02/ES
LICENCES OF THE SYSTEM <ul style="list-style-type: none">• France: Avis Technique• Poland: Aprobata Techniczna• Romania: Agrement Tehnic• Czech Republic: Certifikát• Slovakia: Technické osvedčenie	CSTB: Avis Technique n° 2/03-1061 ITB (Warszawa) - n° AT-15-5631/2002 A.T. ROM-2000 SA (Bucaresti) - n° 020-02/101-2001 CSI (Praha) - n° C-00-0449/Z TSUS (Bratislava) - n° C7.1/01/0343/0/004



SPECIFICATION TEXT

Wall / Roof / Northlight / Curved roof (1) constructed with **SUN MODUL®** selfcarrying modular system of Akraplast Sistemi, **in total thickness (2)**, including: UV protected multi-wall polycarbonate panels, **modular width (3), no. of walls (3), thermal insulation (3), colour (4)**; U shaped channels in galvanized steel with plasticized external surface **colour (5)**, for hooking of the panels with frontal locking system; clip profile in UV protected polycarbonate for stable anchorage of the panels on the steel channels; profiles for framing of the perimeter in natural anodised aluminium; PE inlays, gaskets and any other components necessary to complete the system.

- 1) = alternatively: kind of application
- 2) = alternatively: **40 mm (Standard) - 60 mm (Maxi)**
- 3) = alternatively: see **TECHNICAL DATA (page 3)** and **PANELS TO USE (page 18)**
- 4) = alternatively: **neutral - opaline** - (other colours on request)
- 5) = alternatively: colour **grey** - colour **white**

PANELS TO USE depending on required snow and wind loads		10/500 3 walls	16/500 4 walls	25/500 5 walls	12/1000 honey comb	16/1000 honey comb	32/1000 5X walls	40/1000 5X walls
for Wall / Northlight	with Standard Steel Channel	●	●	●	●	●	●	●
	with Maxi Steel Channel	-	●	●	-	●	●	●
for Flat Roof	with Standard Steel Channel	●	●	●	-	●	●	●
	with Maxi Steel Channel	-	●	●	-	●	●	●
for Curved Roof	with Standard Steel Channel	●	●	●	●	●	-	-
	with Maxi Steel Channel	-	●	●	-	-	-	-

- admitted
- not admitted

TECHNICAL HANDBOOK

A **TECHNICAL HANDBOOK** (also on CD) which can be supplied on request, is available with detailed technical information and examples about the following topics:

- PROPERTIES of the SYSTEM
- ELEMENTS of the SYSTEM
- APPLICATIONS
- ASSEMBLY INSTRUCTIONS



The use of the handbook is recommended for architects for design of projects incorporating the SUN MODUL® system and for roofing contractors.

RESPONSIBILITY CLAUSE

The values and recommendations given are to the best of our knowledge, true and accurate. Since the conditions under which the products may be used are beyond our control, recommendations are made without guarantee. These indications do not exempt the customer from ensuring that the materials selected meet their requirements and the laws and regulations in force.

AKRAPLAST Sistemi S.p.A. reserves the right to change specifications at any time.

11/2011 R2

www.gepcomunicazione.it

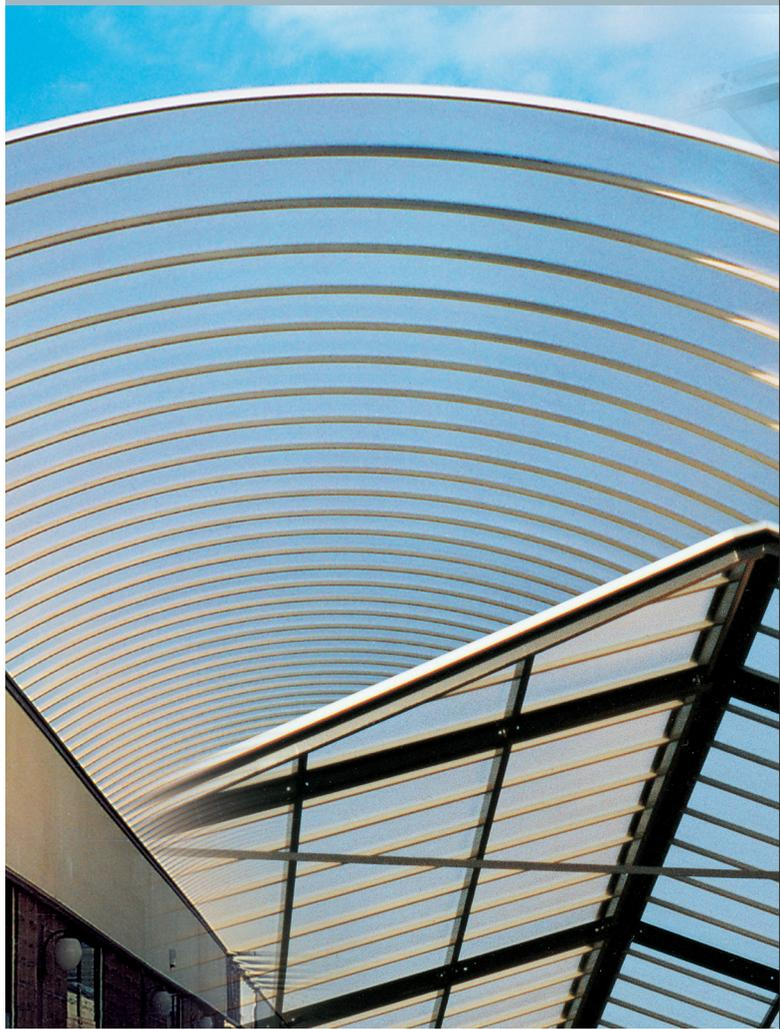

www.akraplast.com



AKRAPLAST®

AKRAPLAST Sistemi S.p.A.

I - 20026 NOVATE MILANESE (MI) - Via Cascina del Sole, 70
Tel. (+39) 02 35 13 91 1 - Fax (+39) 02 35 13 91 50
E-mail: info@akraplast.com - www.akraplast.com